



RM-7085

B. E. - III (Sem. VI) (ECC) Examination

May / June - 2010

Analog Integrated Circuit

Time : 3 Hours]

[Total Marks : 100

Instructions :

(1)

नीचे दर्शावेक निशानीवाणी विगतो उत्तरवडी पर अवश्य लपवी.  
Fillup strictly the details of signs on your answer book.

Name of the Examination :  
B. E. - 3 (Sem. 6) (ECC)

Name of the Subject :  
Analog Integrated Circuit

Subject Code No. : 7 0 8 5 Section No. (1, 2,.....): 1&2

Seat No. :  
[ ] [ ] [ ] [ ] [ ] [ ]

Student's Signature

- (2) Attempt all questions.  
(3) Assume necessary data if required.  
(4) Figures to the right indicate full marks.

SECTION - I

- 1 (a) Attempt all questions : 20
- (i) Write the condition required to use 555 times 3  
in monostable mode as a frequency divide by N.  
Draw i/P and o/P waveform.
- (ii) In second order low pass filter the value of 2  
 $R_1 = 2K$  and the  $R_F = 10 K$  then what will  
be the pass band gain? This data is possible?
- (iii) Find the value of I in given figure. 3

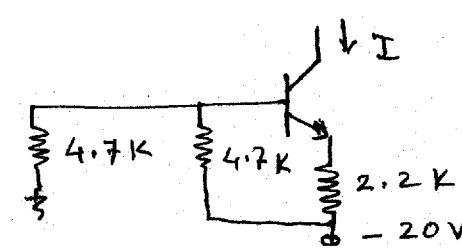

- (iv) The common mode input to a certain differential amplifier, having differential gain of 125 is  $(4\sin 200\pi t)\text{V}$ . Determine the common mode output if CMRR is 60 dB. 4
- (v) Explain binary weighted DAC and derive the equation for analog output voltage. 6
- (vi) Which type of ADC is used for high speed application? Justify the answer. 3
- 2 Attempt any two :** **16**
- (i) Explain different applications of astable multivibrator using 555 timer.
- (ii) Derive the cutoff frequency for second order high pass filter. Draw frequency response.
- (iii) For a differential amplifier circuit operated from  $\pm 10\text{V}$ , assume matched pair of transistor with  $V_{BE} = 0.7\text{ V}$ . The  $R_C = 47\text{ K}\Omega$ . Calculate  $R_E$  so that the  $V_{CEQ} = 8.6\text{ V}$  for each transistor. Assume  $h_{fe} = 100$ .
- 3 Attempt any two :** **14**
- (i) Explain double integrator type ADC with necessary equations and waveforms.
- (ii) Find the application of given circuit and its frequency response with values of frequencies.

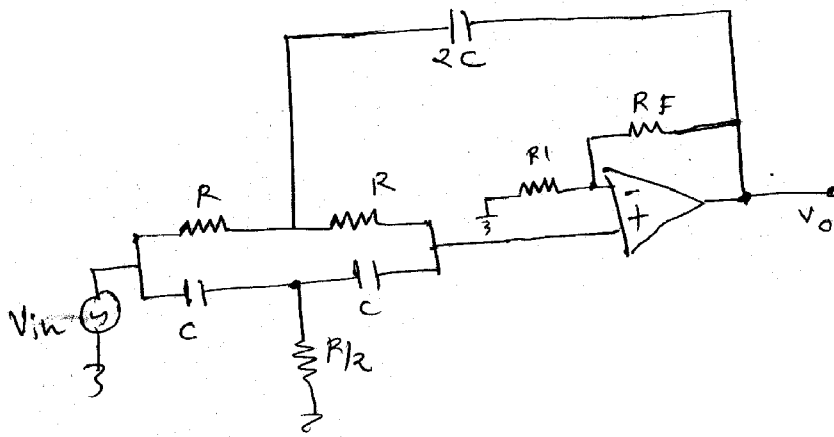

- (iii) Draw a circuit diagram of Timer using 555 IC. Calculate the component values if the controlled door should remain open for 15 sec. after a trigger signal is applied.  $V_{CC} = 15V$  Take  $C = 100 \mu F$ .

## SECTION - II

4 (a) Attempt the following : 10

- (i) In the circuit shown in fig (1) show that

$$V_o = a_1 v_1 + a_2 v_2 + a_3 v_3.$$

Determine the value of  $a_1, a_2$  and  $a_3$  and

compute the value of  $V_o$  if

- (a)  $R_y$  is S/C (b)  $R_y$  is removed (c)  $R_i$  is S/C

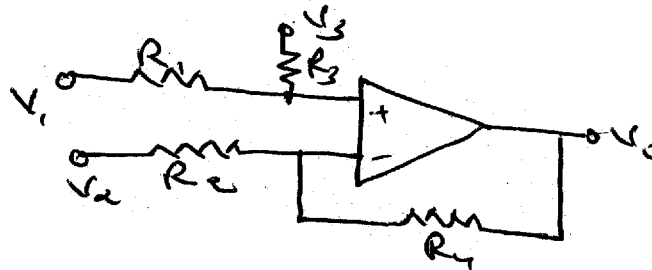

- (ii) Design an inverting amplifier where gain is variable from unity to 100 for DC applications. Suggest some method to convert it into a non-inverting amplifier with the same gain variation.
- (iii) Derive  $V_o = -\alpha R'C - \alpha(R'/R)t$  for the circuit shown in figure (2) if  $V_i = \alpha t$ .

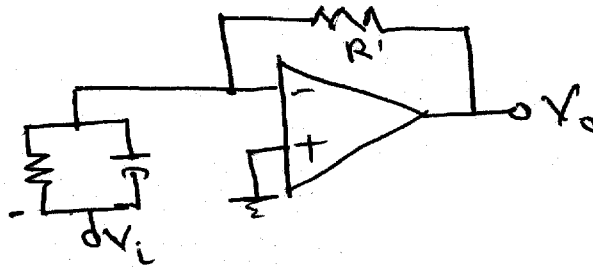

- (iv) Design an op-amp circuit, which gives an output  $e_o = \sin t - \cos t$  from the available inputs  $e_1 = \sin t$  and  $e_2 = \cos t$ . Give all the component values and make the reasonable assumptions whenever require.
- (v) Find  $V_o$  for the circuit shown in Fig. 3.

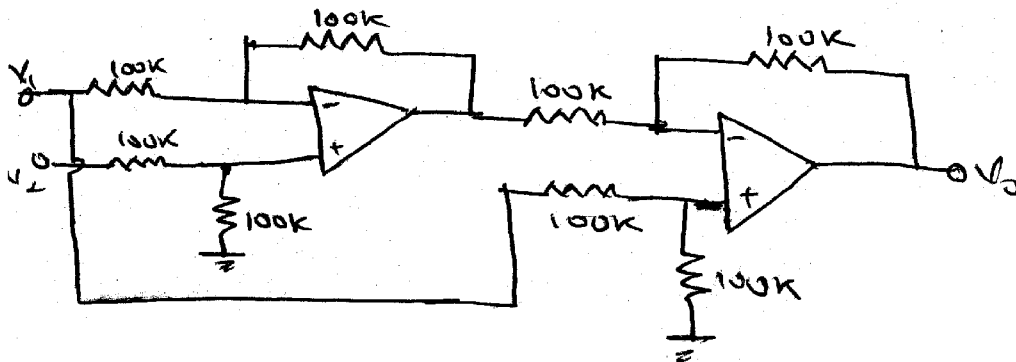

- (b) Design a phase shift oscillator using op-amp and find out frequency of oscillation for the same. 5
- (c) For the circuit shown in figure (4)  $R = 10 \text{ K}\Omega$ . Find  $R_1$  so that  $V_o = -100 V_{in}$ . 5

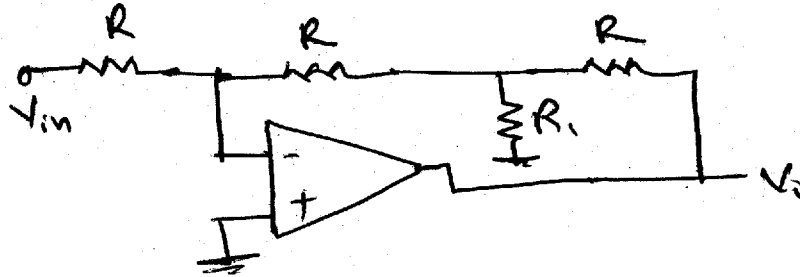

2 Attempt any two : 16

- (i) For the circuit shown in figure (5), prove that  $i_L = -2 \frac{V_{in}}{R_1}$ ,

$$\text{where } \frac{1}{R} = \left(1 + \frac{2R_3}{R_4}\right) \cdot \frac{1}{R_1}$$

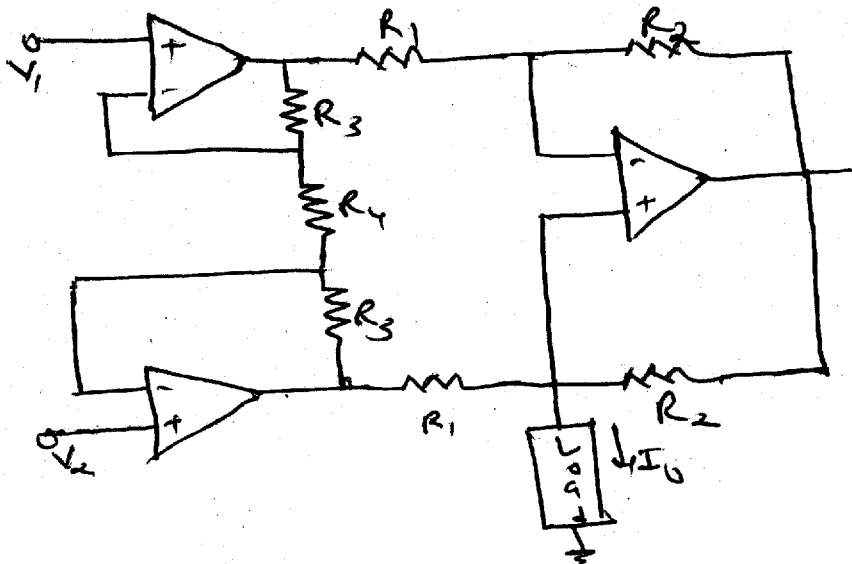

(ii) Show that input impedance for the noninverting amplifier shown in figure (6) is

$$R_{if} = R_i \left\{ 1 + \frac{R_1}{R_1 + R_f} A_v \right\}$$

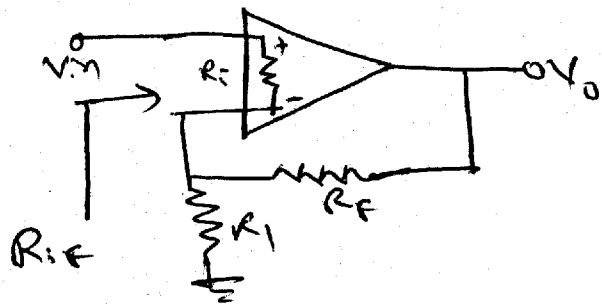

(iii) Design a circuit for the waveforms shown in figure (7) for sinusoidal input.

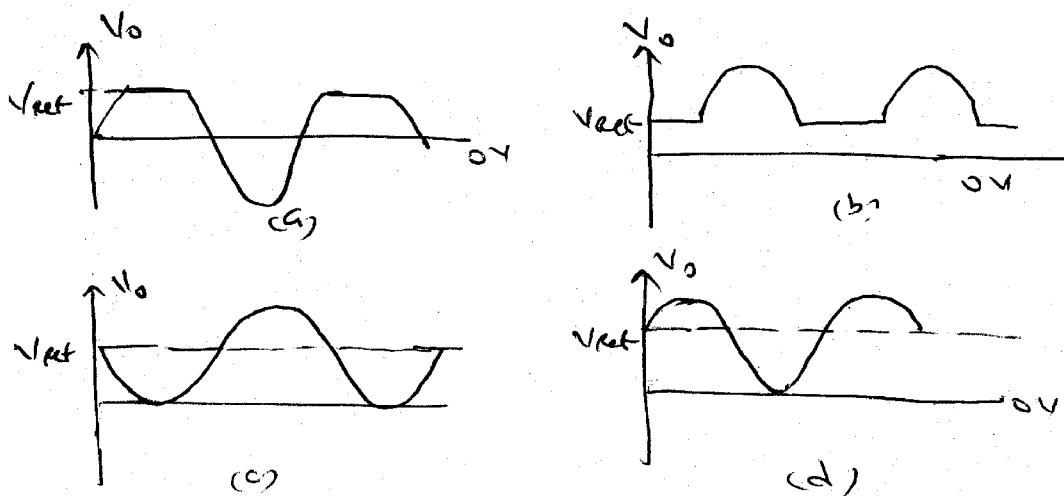

3 Attempt any two :

14

(i) Design a differentiator circuit, which perform the mathematical operation of differentiation. Mention the drawbacks of basic differentiator and give the remedy to overcome the same.

- (ii) Design a circuit of figure (8) in such a manner that output is full wave rectification of sinusoidal input signal.

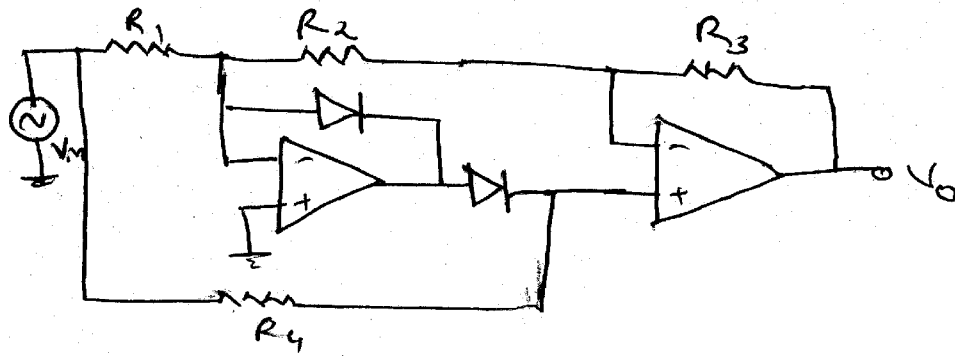

- (iii) Design a circuit for the monostable multivibrator using op-amp.

---